

Fraser Rattan Cabinet ASSEMBLY INSTRUCTIONS

CARE INSTRUCTIONS:















TO BE ASSEMBLED ON A CLEAN, DRY AND SMOOTH SURFACE.
WIPE CLEAN WITH A SOFT DAMP CLOTH. NEVER USE SCOURERS,
ABRASIVES OR CHEMICAL SOLVENTS.
CHECK AND TIGHTEN ALL PARTS REGULARLY.
KEEP AWAY FROM MOISTURE AND DIRECT SUNLIGHT.
STORE IN A DRY PLACE. FOR INDOOR AND DOMESTIC USE ONLY.

WARNING:

DO NOT STAND, SIT OR LEAN ON THIS UNIT.
DO NOT USE THIS UNIT AS A STEP LADDER OR AS A CHOPPING
SURFACE. KEEP AWAY FROM CHILDREN AND BABIES. ADULT
ASSEMBLY REQUIRED. USE ONLY ON A FLAT SURFACE.
DO NOT USE THIS UNIT UNLESS ALL BOLTS AND SCREWS ARE
FIRMLY SECURED.

MAXIMUM SAFE LOAD: 22 lb. FOR TOP PANEL, 11 lb. FOR SHELF.

1 Hardware List

	A	∅6x30mm	17pcs		B	M6x35mm	8pcs
	C	∅15x9.5mm	8pcs		D	M7x50mm	9pcs
	E		1pc		F		5pcs
	G		4pcs		H	M3x12mm	38pcs
	J		2pcs		K		8pcs
	M		4pcs		N		2pcs
	P		2pcs		Q	M4x40mm	2pcs

2

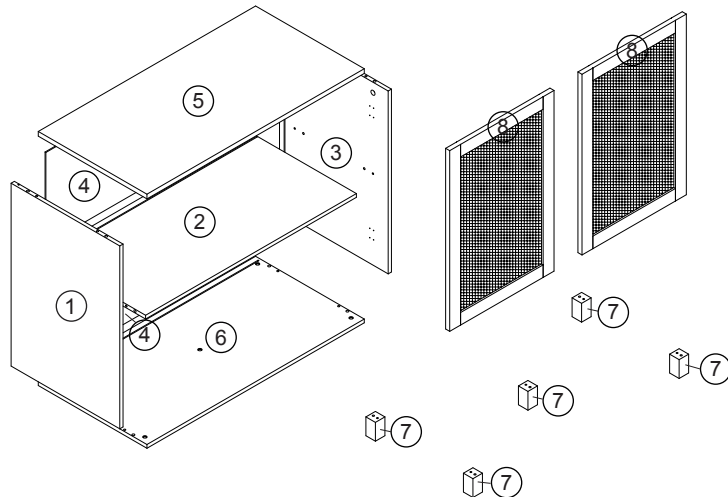

3

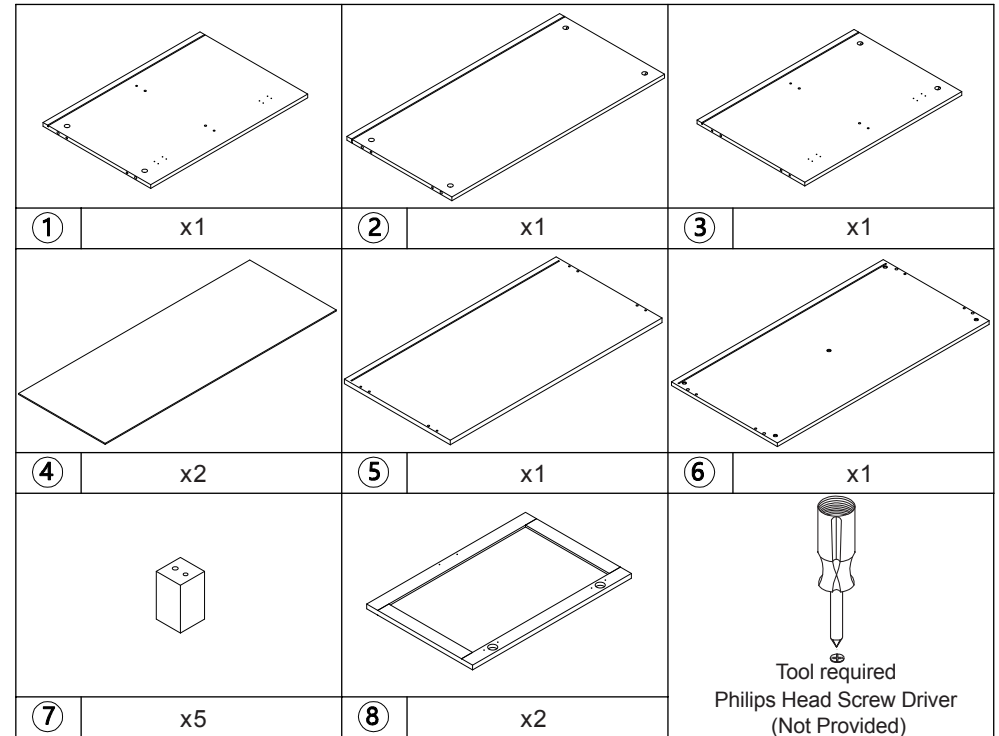

**ATTENTION: DO NOT TIGHTEN THE SCREWS FULLY
DURING ASSEMBLY. FULLY TIGHTEN SCREWS AFTER
THE FINAL ASSEMBLY STEPS.**

Step 1

- Ax2
- Bx2

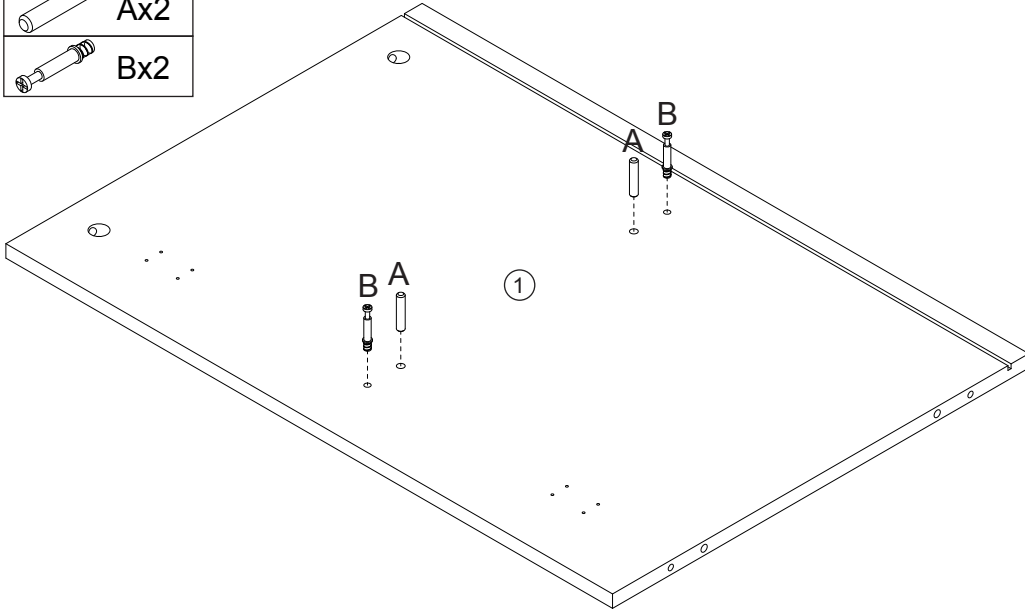

Step 2

- Cx2

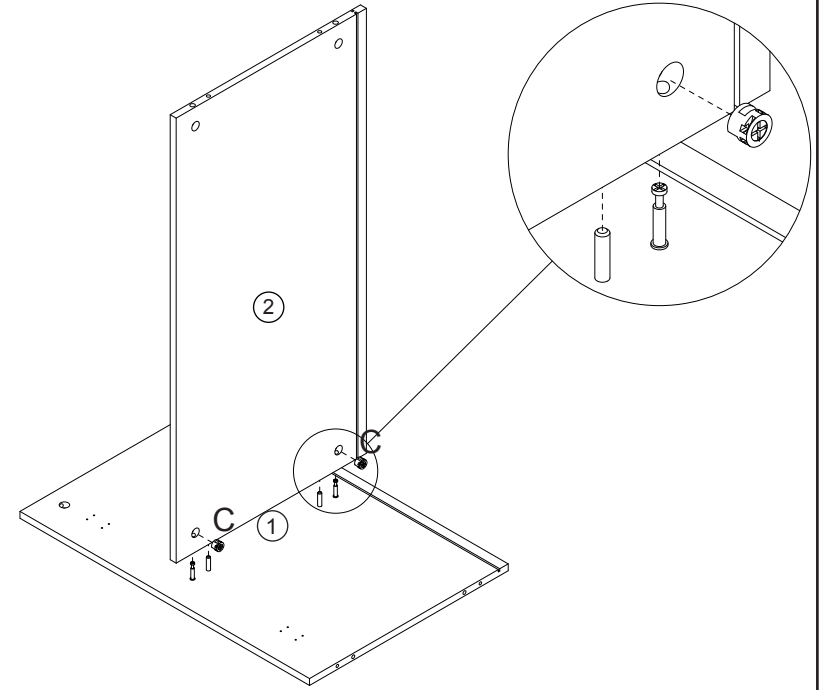

Step 3

- Ax2
- Bx2

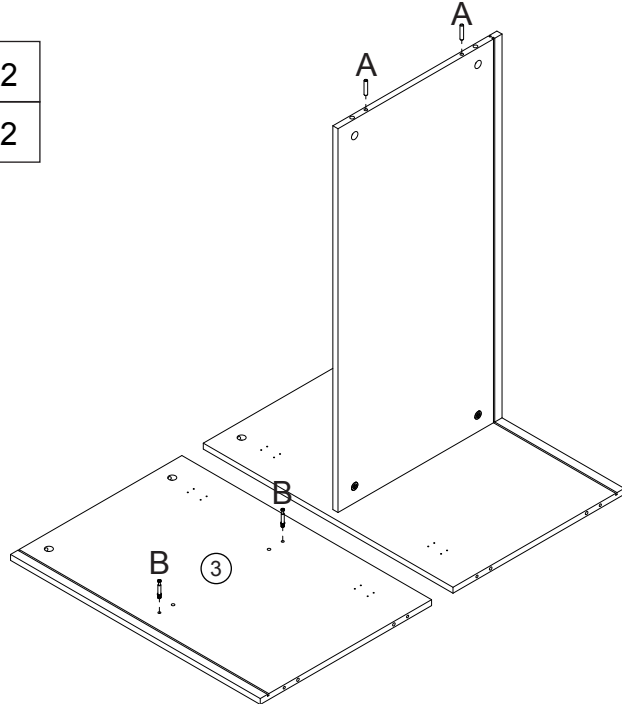

Step 4

- Cx2

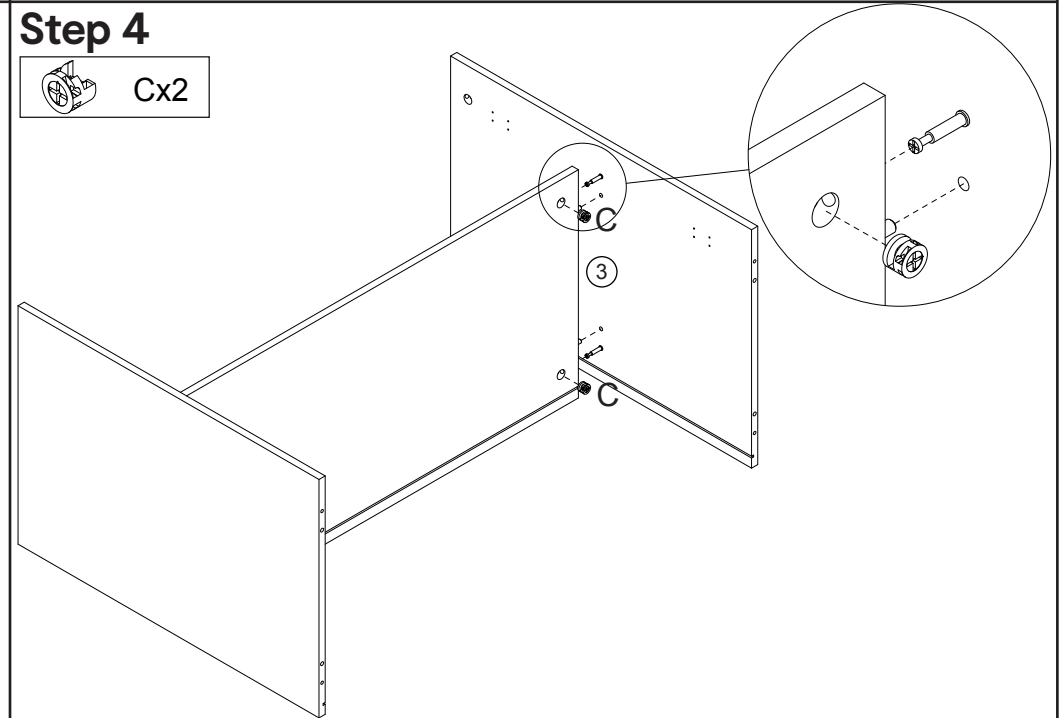

Step 5

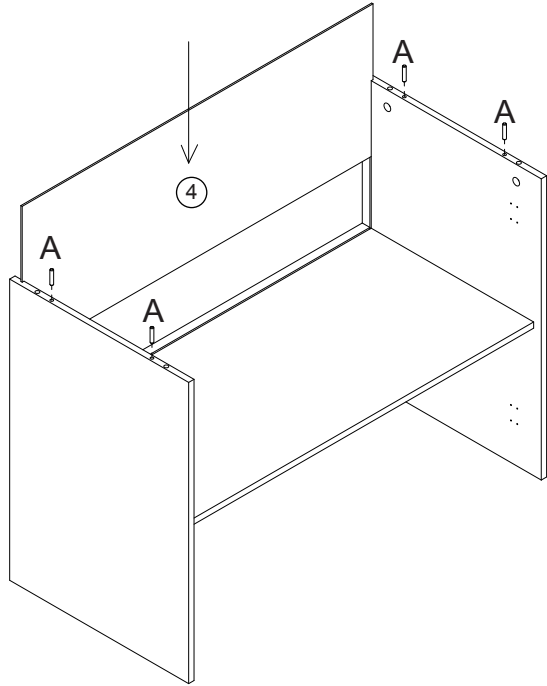

Step 6

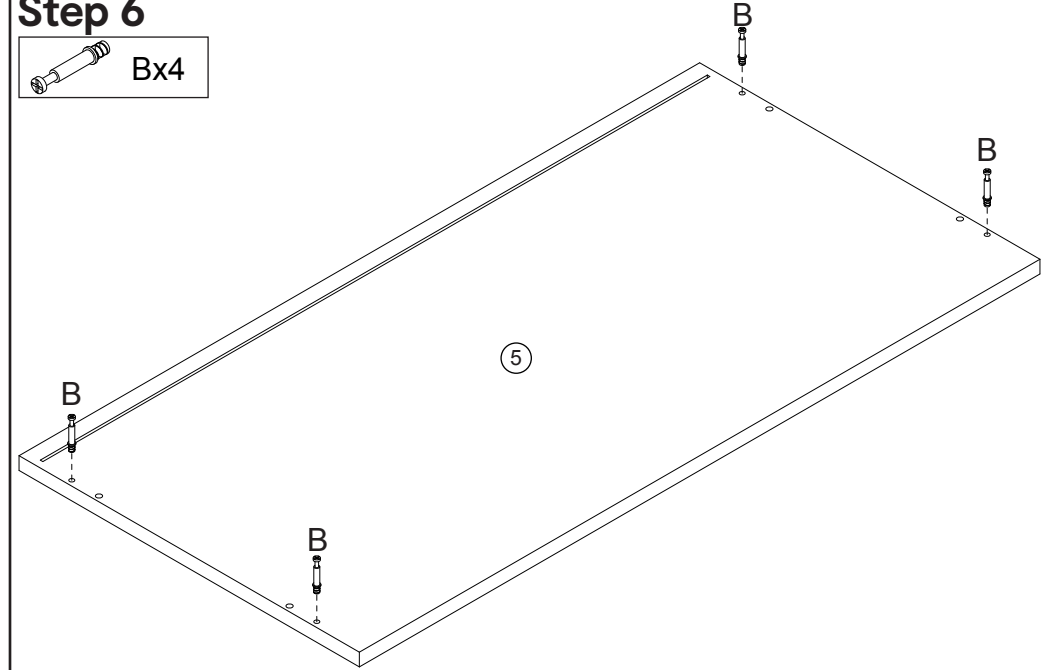

Step 7

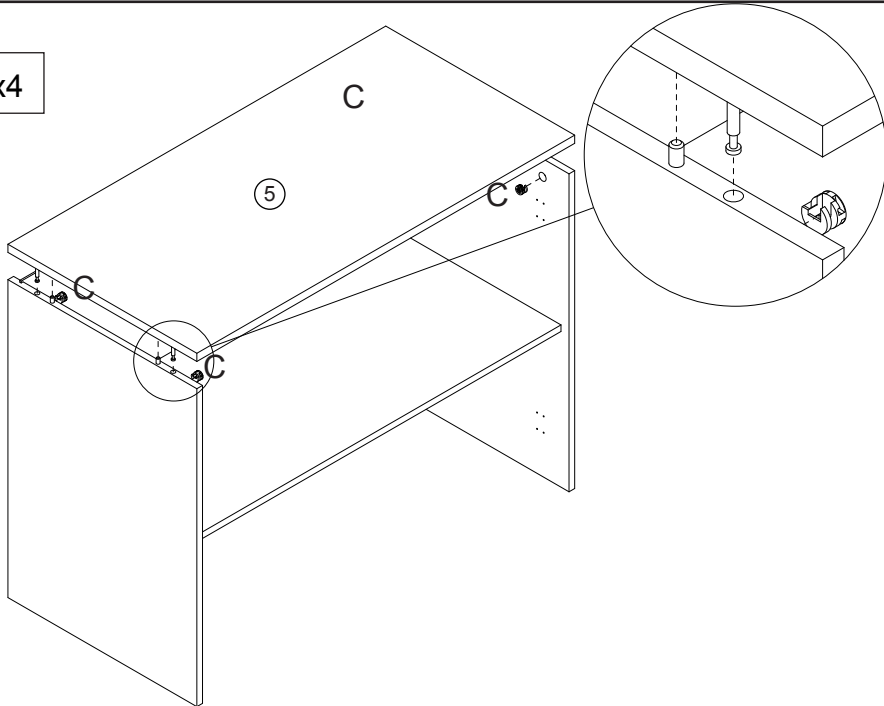

Step 8

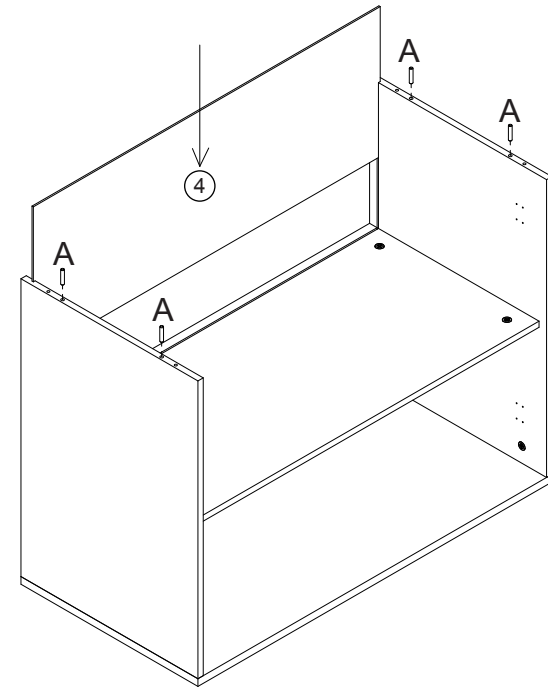
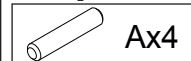

Step 9

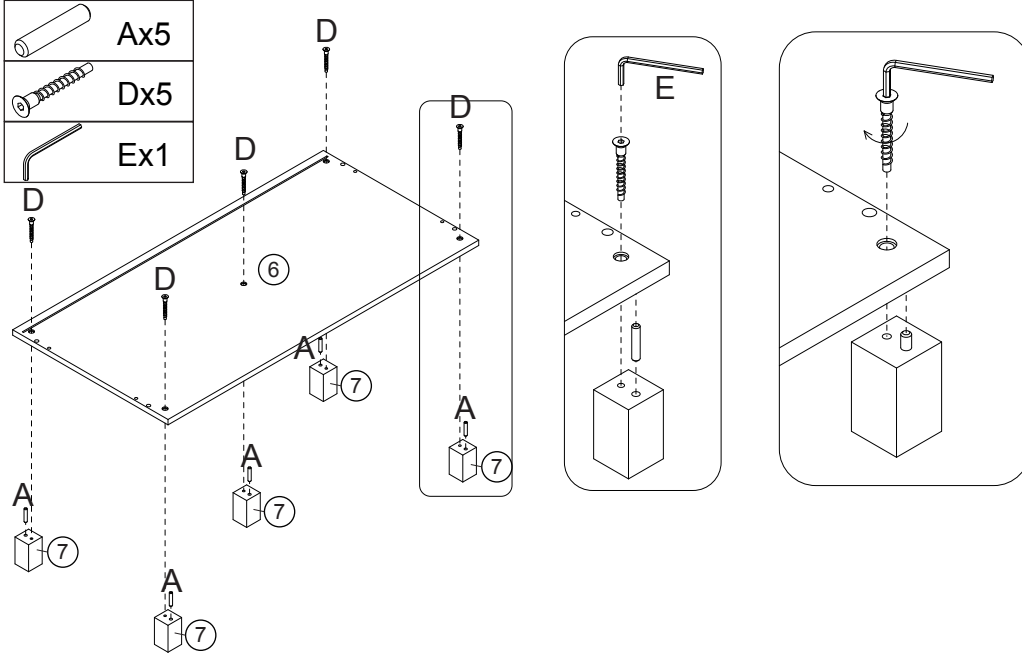

Step 10

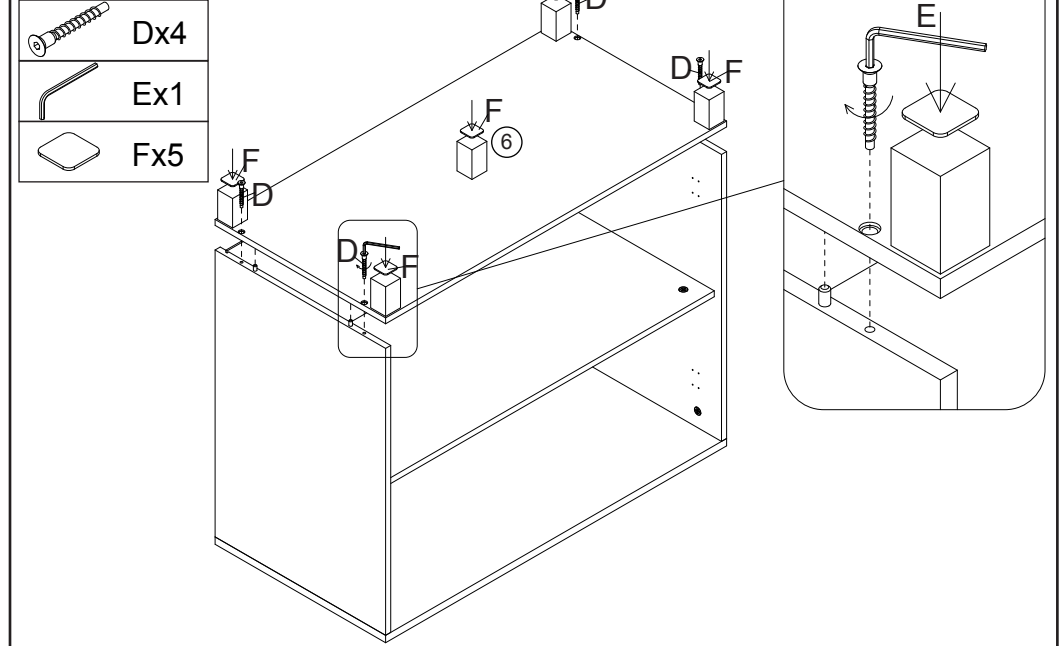



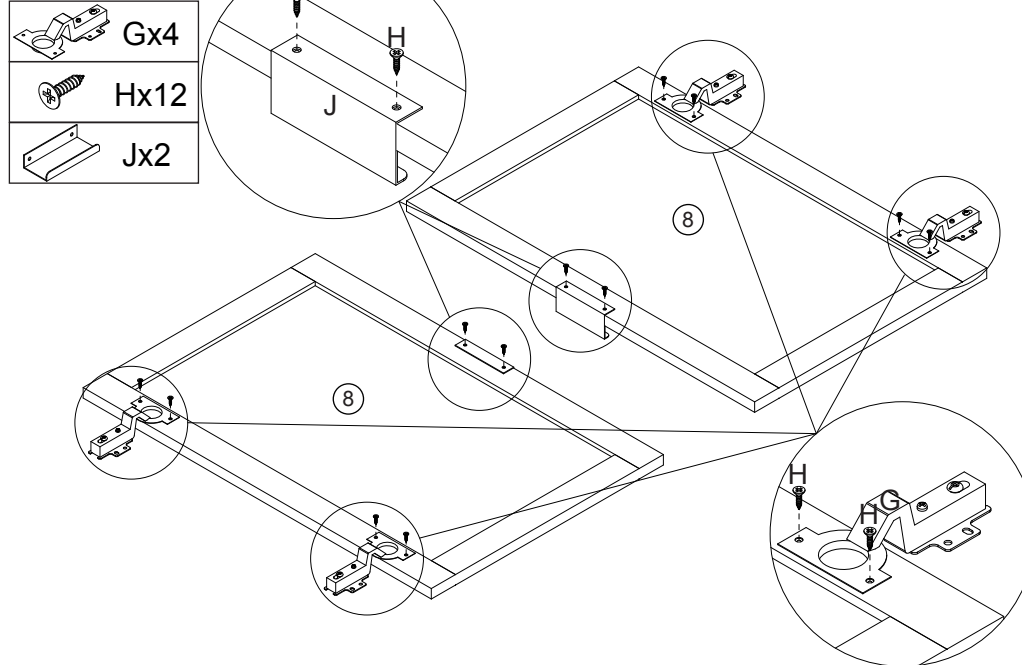

Step 11

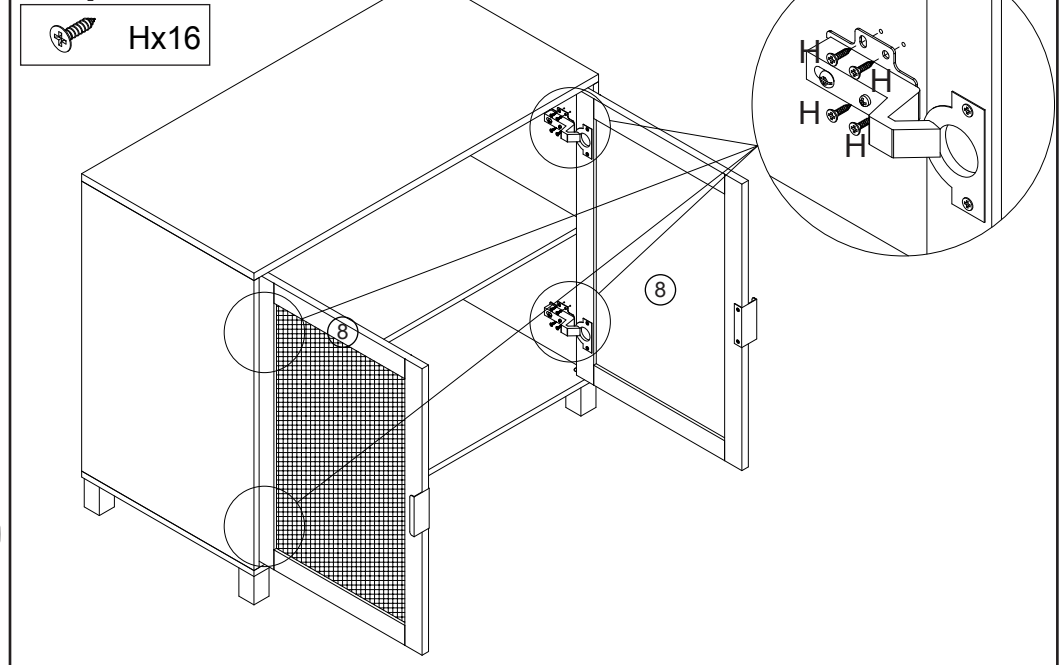

Step 12



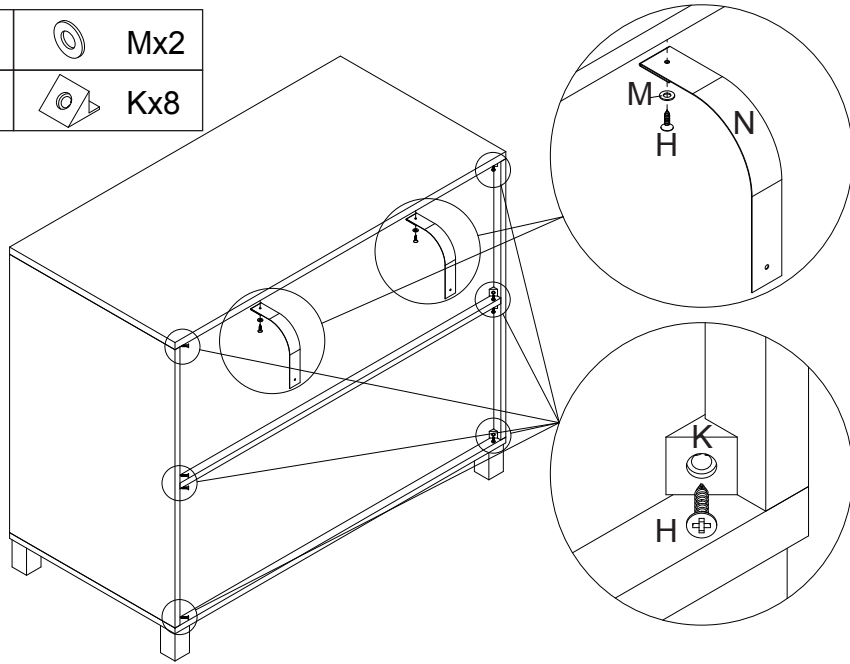

Step 13

 Hx10	 Mx2
 Nx2	 Kx8



Step 14

 Mx2
 Px2
 Qx2

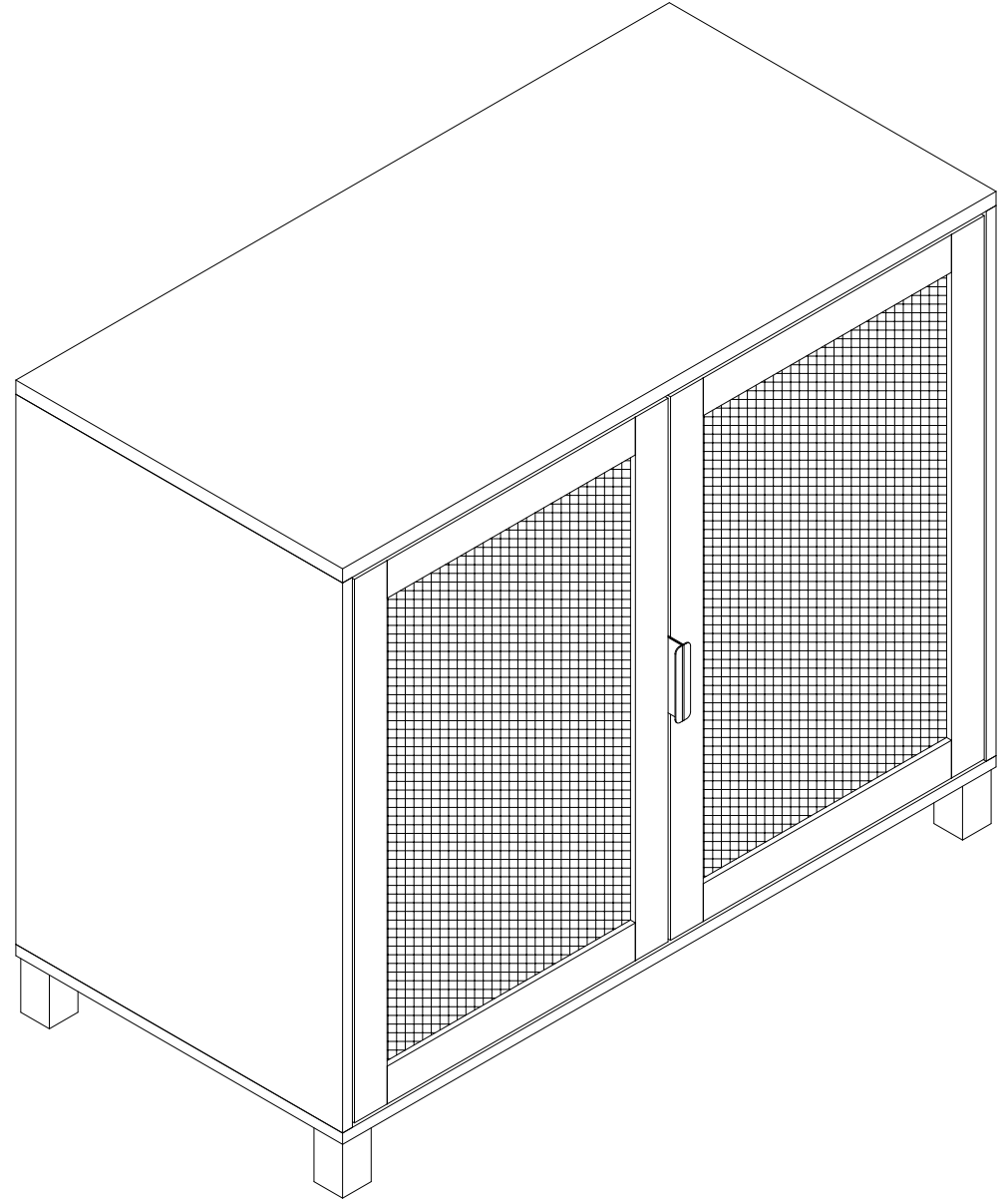
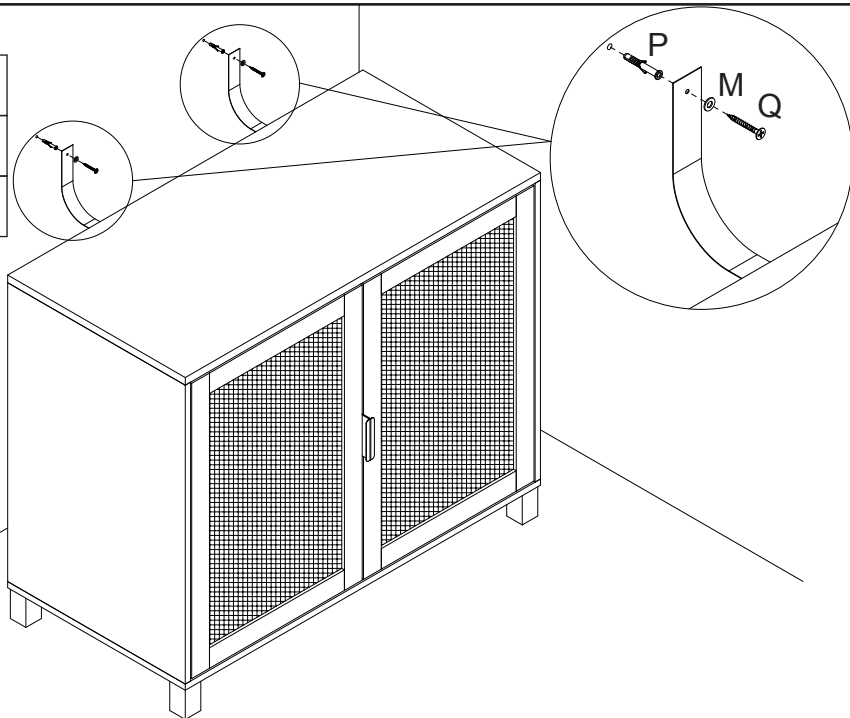

Hinger Adjustment Tips

Noted: The door might be scraping, bumping, misaligned when first assembly. Please follow the below tips:

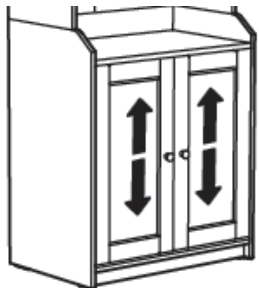

Adjust the door up and down

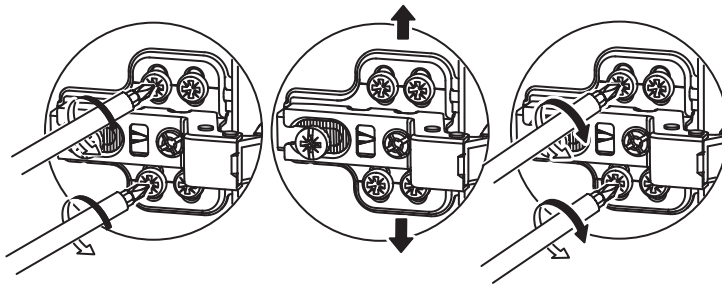

1. Loosen the two mounting screws on both hinges, but only slightly. ...
2. Gently close the cabinet door.
3. With the door still closed, adjust the cabinet door to the desired height.
4. Open the cabinet door again, being careful not to jostle the door out of position.
5. Retighten the screws by hand.

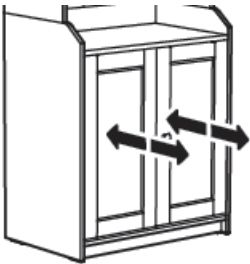

Move the door in and out

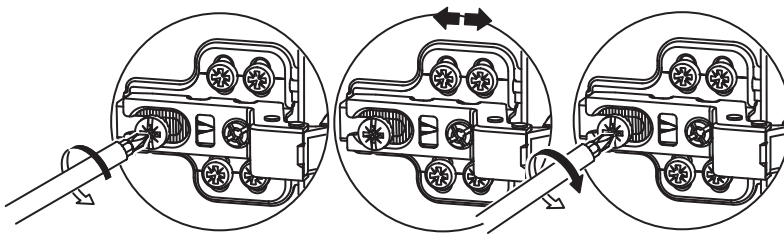

If the door doesn't meet the box at the top, adjust the top hinge toward the cabinet and/or adjust the bottom hinge away from the cabinet. If the door is gapped at the bottom, do the reverse.

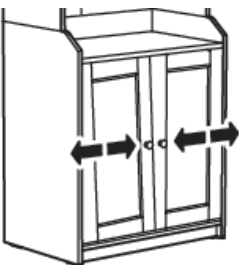

Move the door right or left

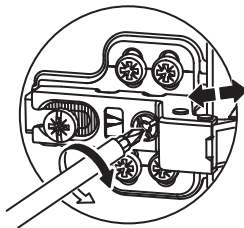

You can adjust one or both hinges on each door, depending on how much correction it needs. If the door seems to be tilting down to the right, turn the side-to-side screw on the top hinge so the hinge pulls closer to the side of the cabinet box, moving the top of the door to the left.

TOPPLING FURNITURE WARNING:

- It is strongly recommended that this product is permanently fixed to the wall.
- Please seek professional advice if you are in doubt of what fixing device to use.
- Regularly check that anchors are securely maintained.
- Use safety drawer locks to prevent children climbing.
- Stability of tall items may be affected by thick pile carpet or uneven floors.
- Do not place unanchored televisions on furniture.

CAUTION: For your safety when attaching the anchor fixings, please note the following:

- Check any electrical wires or plumbing inside the wall before drilling any holes (if you are unsure please seek professional advice from a qualified tradesperson).



TOPPLING HAZARD

WARNING:
PLEASE SECURE YOUR
FURNITURE WITH THE SUPPLIED
WALL FIXING.

INSTRUCTIONS D'ENTRETIEN :















ASSEMBLEZ CE PRODUIT SUR UNE SURFACE PROPRE, SÈCHE ET LISSE. NETTOYEZ CE MEUBLE AVEC UN CHIFFON DOUX ET HUMIDE. N'UTILISEZ JAMAIS DE PRODUITS À RÉCURER, D'ABRASIFS OU DE SOLVANTS CHIMIQUES. VÉRIFIEZ ET SERREZ RÉGULIÈREMENT TOUTES LES PIÈCES. CONSERVEZ CE MEUBLE À L'ABRI DE L'HUMIDITÉ ET DE LA LUMIÈRE DIRECTE DU SOLEIL. CONSERVEZ CE MEUBLE DANS UN ENDROIT SEC. POUR UN USAGE INTÉRIEUR ET DOMESTIQUE UNIQUEMENT.

AVERTISSEMENT :

NE VOUS TENEZ PAS DEBOUT, NE VOUS ASSEYEZ PAS ET NE VOUS APPUYEZ PAS SUR CE MEUBLE. N'UTILISEZ PAS CE MEUBLE COMME ESCABEAU OU COMME SURFACE DE COUPE. GARDEZ-LE ÉLOIGNÉ DES ENFANTS ET DES BÉBÉS. ASSEMBLAGE PAR UN ADULTE REQUIS. UTILISEZ CE PRODUIT UNIQUEMENT SUR UNE SURFACE PLANE. N'UTILISEZ PAS CE MEUBLE SI TOUS LES BOULONS ET VIS NE SONT PAS SOLIDEMENT FIXÉS.

CHARGE MAXIMALE DE SÉCURITÉ : 10 kg POUR LE PANNEAU SUPÉRIEUR, 5 kg POUR L'ÉTAGÈRE.

1 Liste du matériel

	A	∅6x30mm	17pcs		B	M6x35mm	8pcs
	C	∅15x9.5mm	8pcs		D	M7x50mm	9pcs
	E		1pc		F		5pcs
	G		4pcs		H	M3x12mm	38pcs
	J		2pcs		K		8pcs
	M		4pcs		N		2pcs
	P		2pcs		Q	M4x40mm	2pcs

2

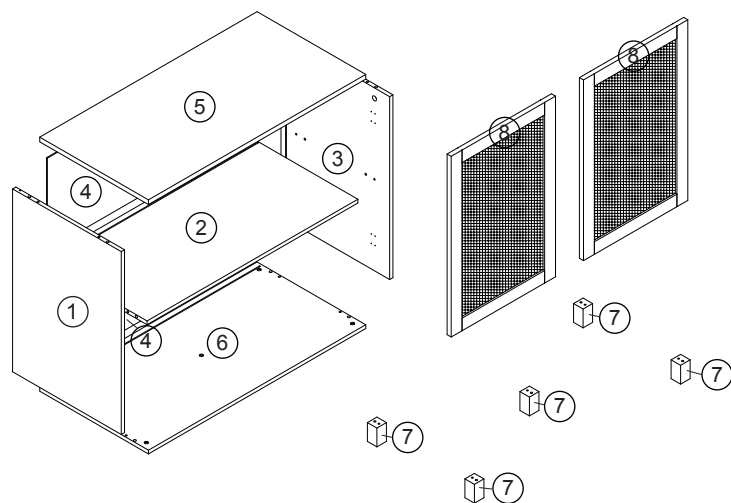

3

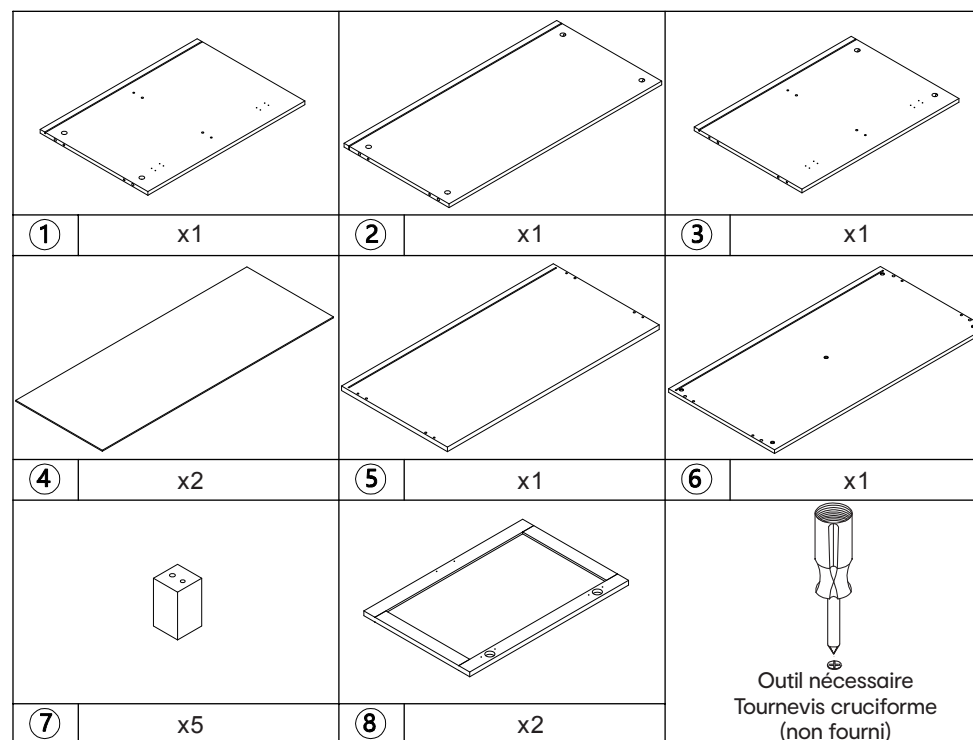

ATTENTION: NE SERREZ PAS COMPLÈTEMENT LES VIS PENDANT L'ASSEMBLAGE. SERREZ COMPLÈTEMENT LES VIS APRÈS LES DERNIÈRES ÉTAPES D'ASSEMBLAGE.

Étape 1

- Ax2
- Bx2

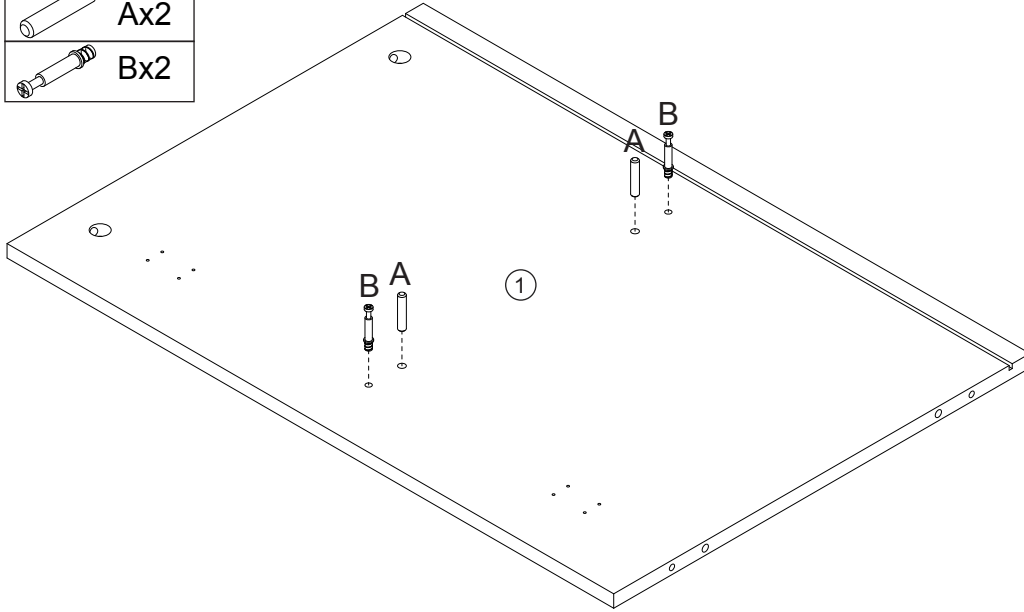

Étape 2

- Cx2

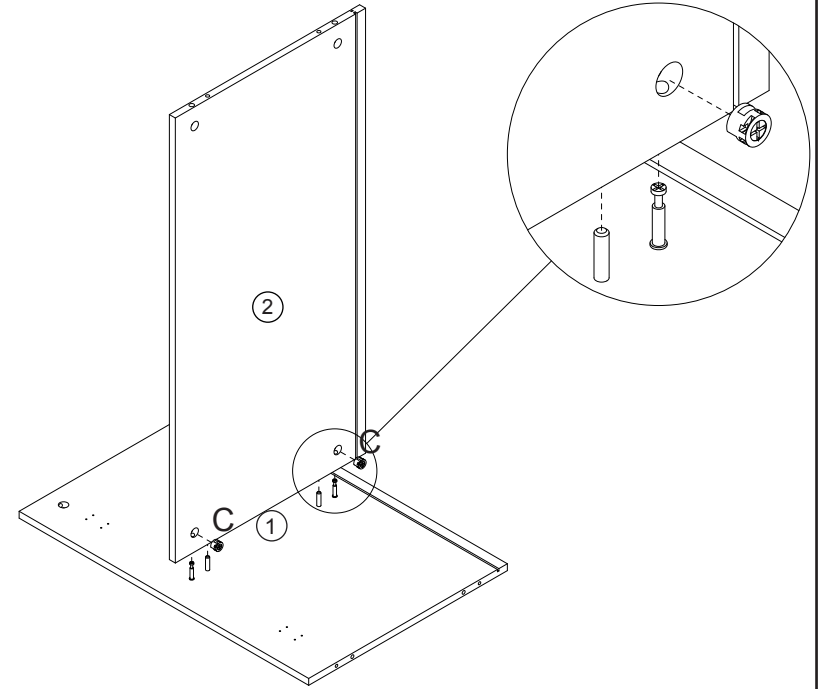

Étape 3

- Ax2
- Bx2

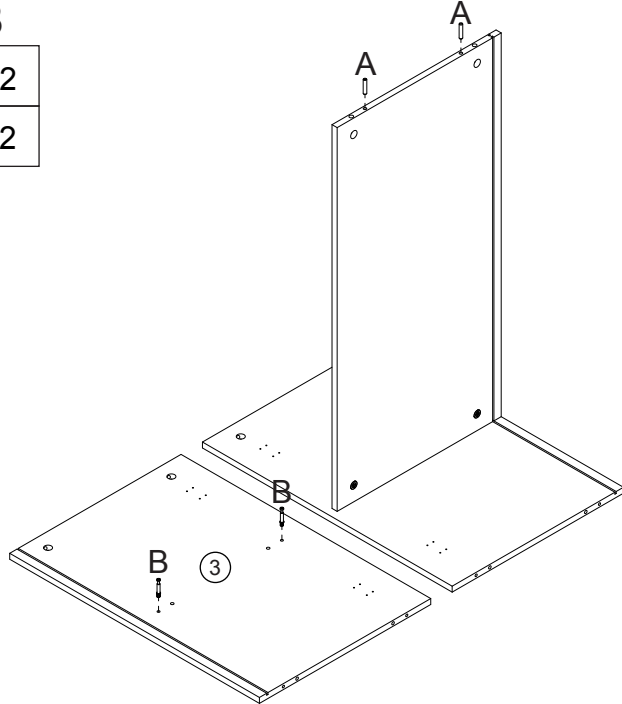

Étape 4

- Cx2

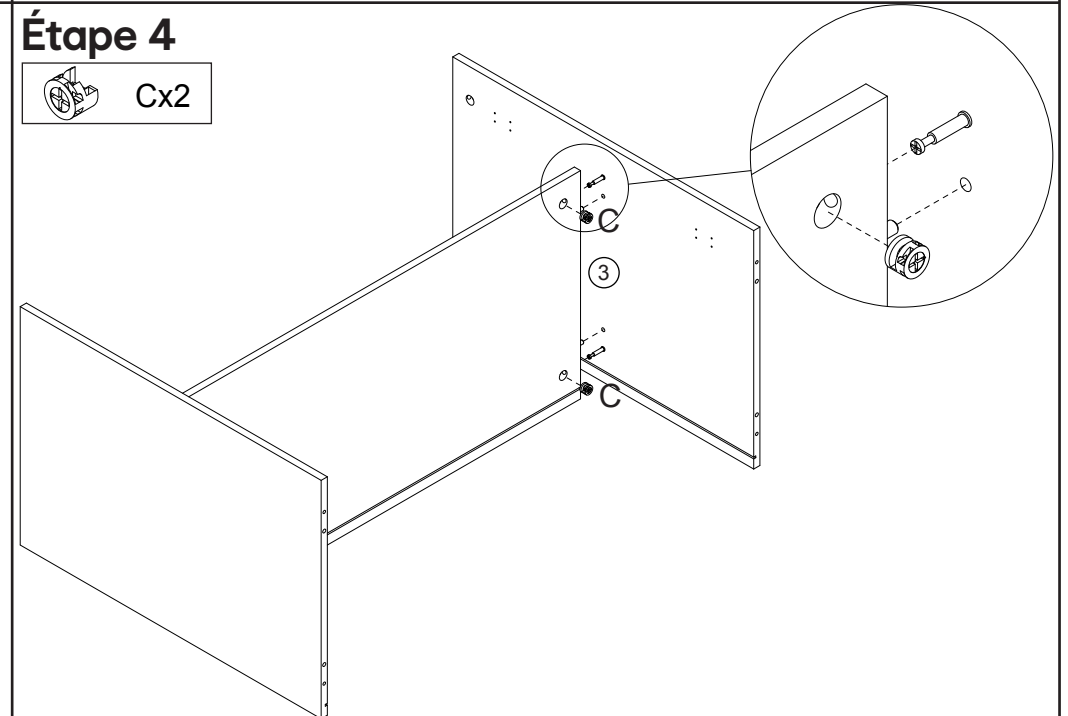

Étape 5

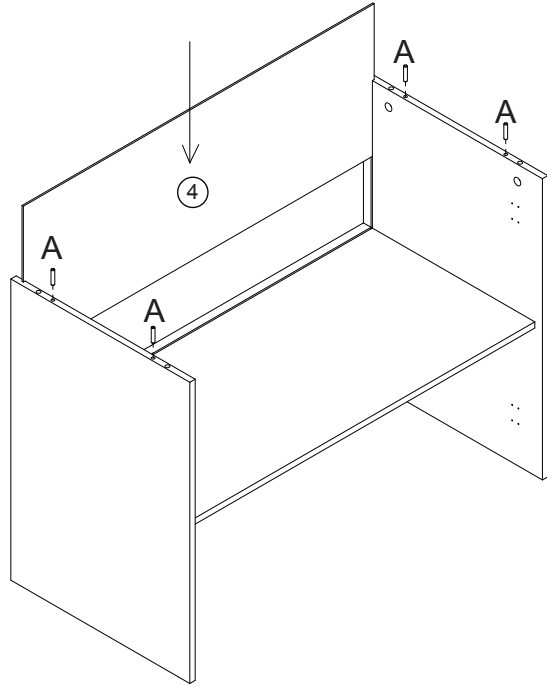

Étape 6

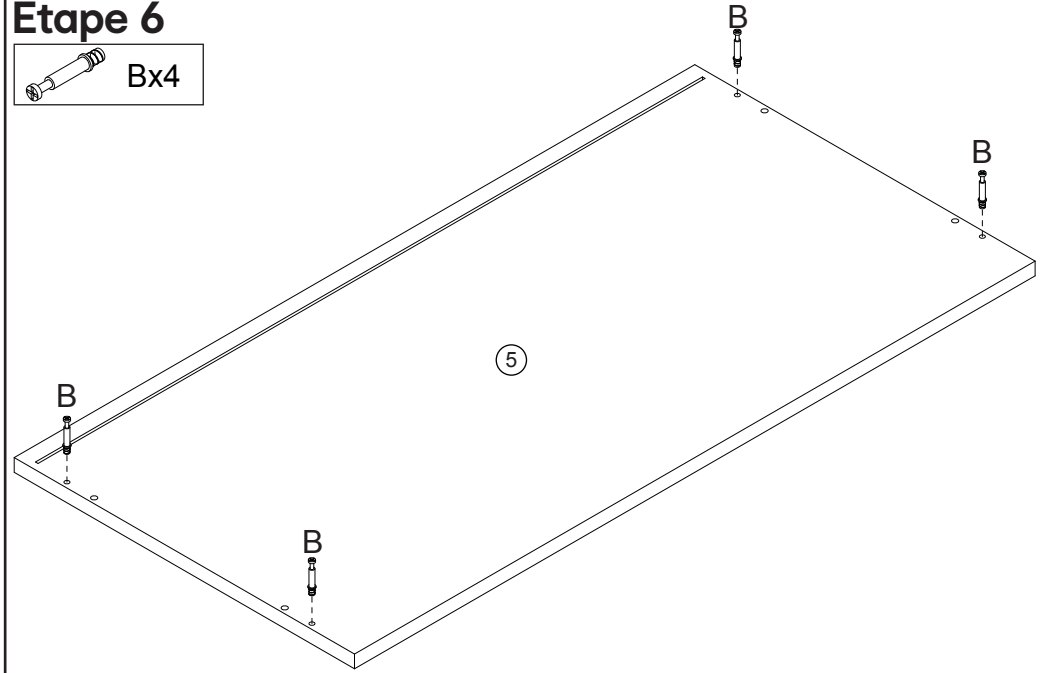

Étape 7

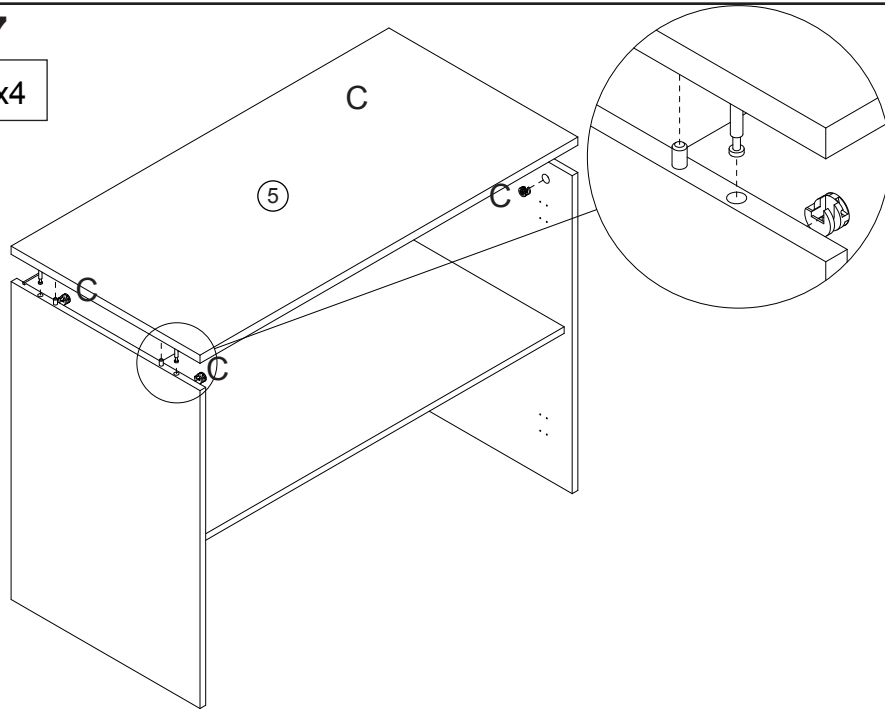
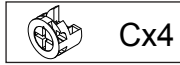

Étape 8

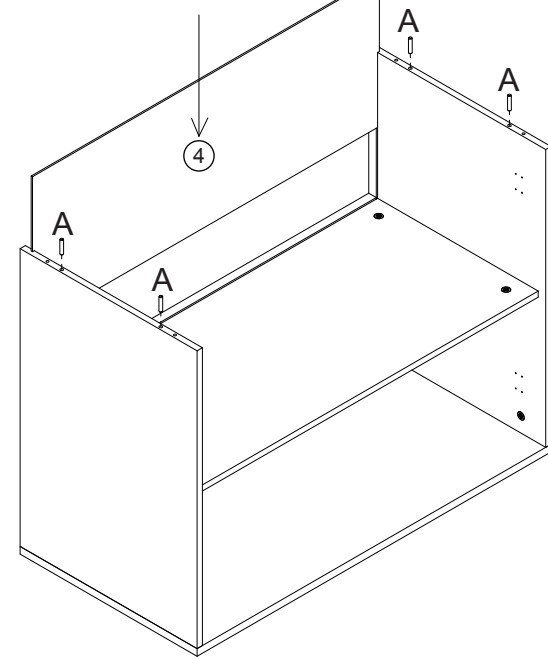
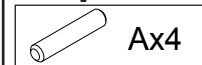

Étape 9

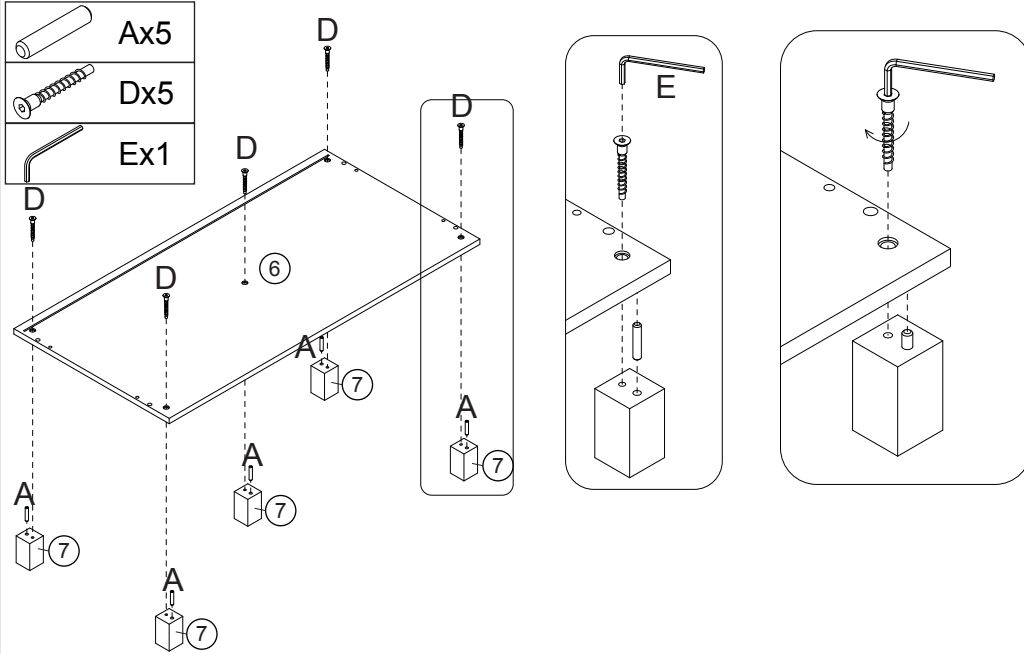

Étape 10

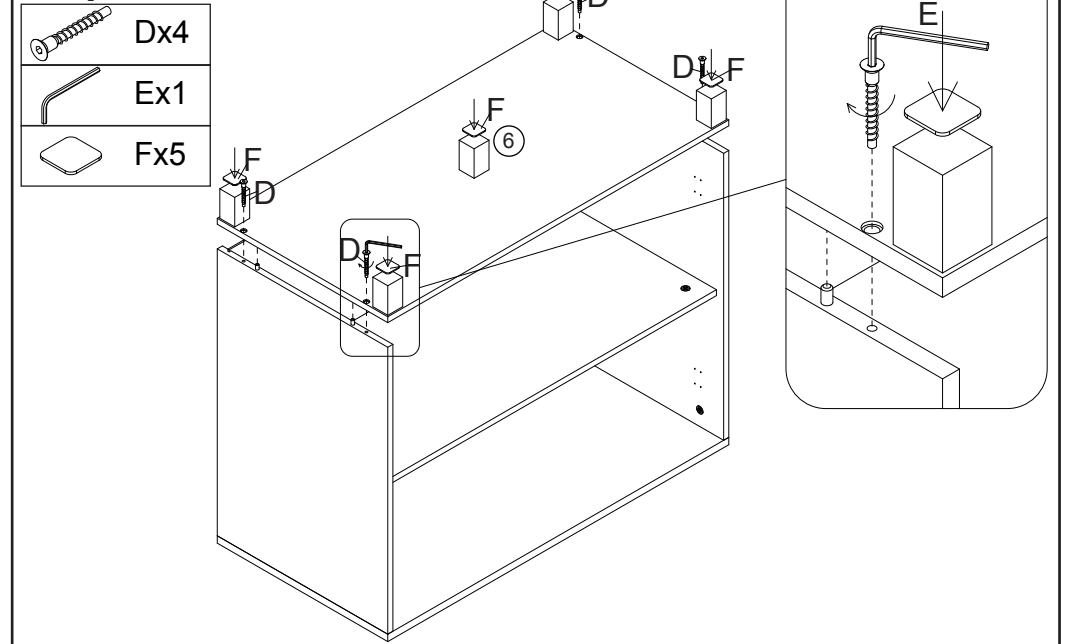



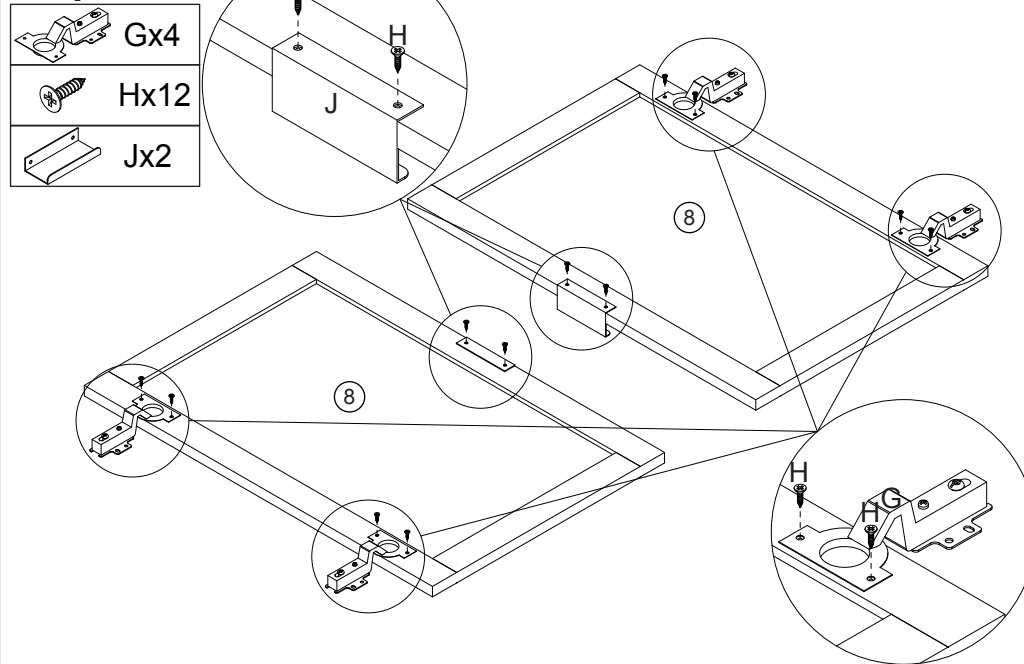

Étape 11

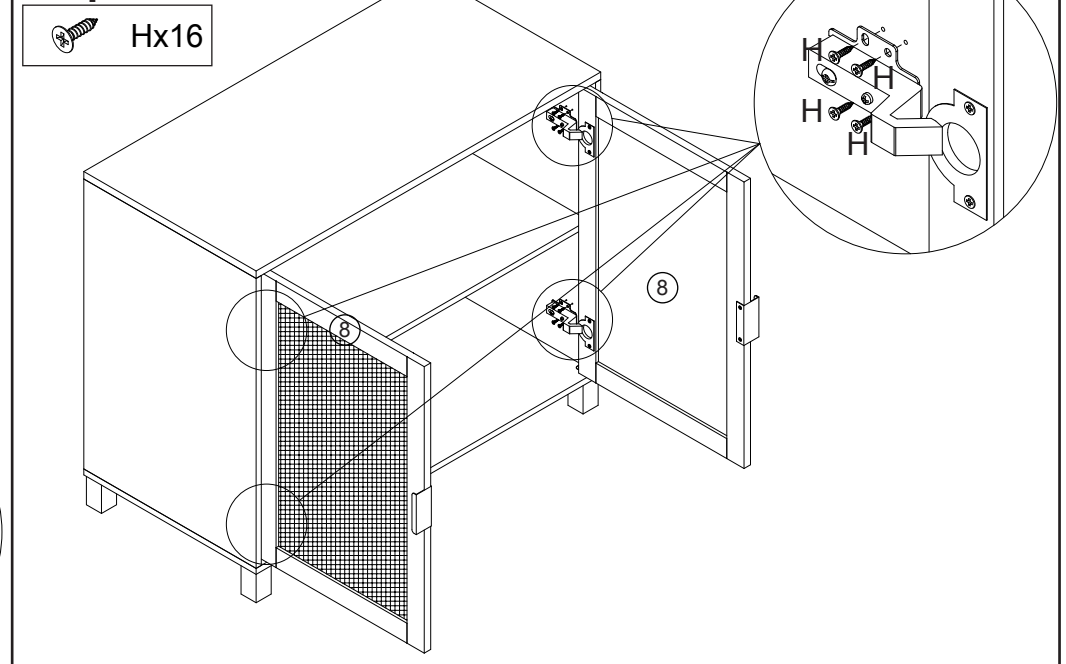

Étape 12



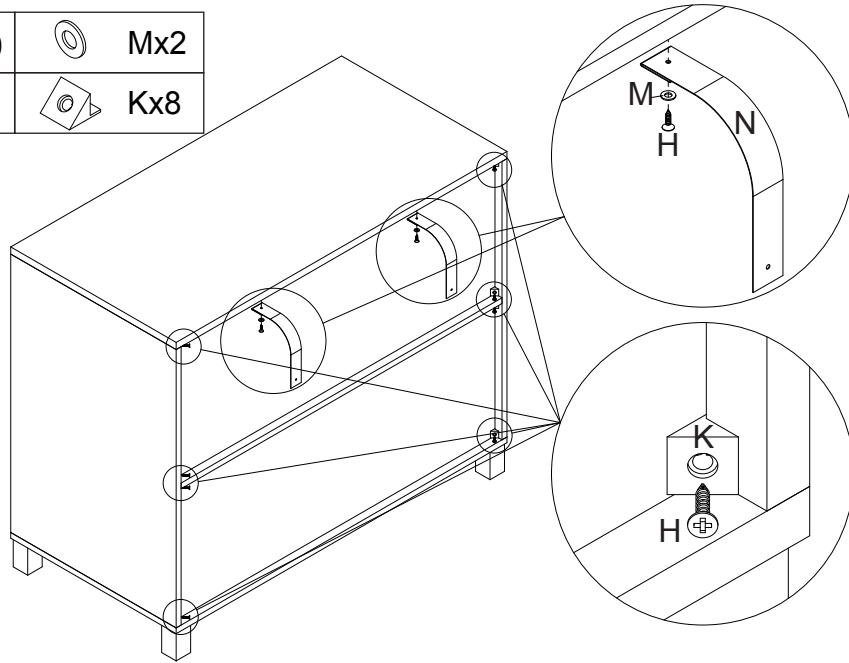

Étape 13

	Hx10		Mx2
	Nx2		Kx8



Étape 14

	Mx2
	Px2
	Qx2

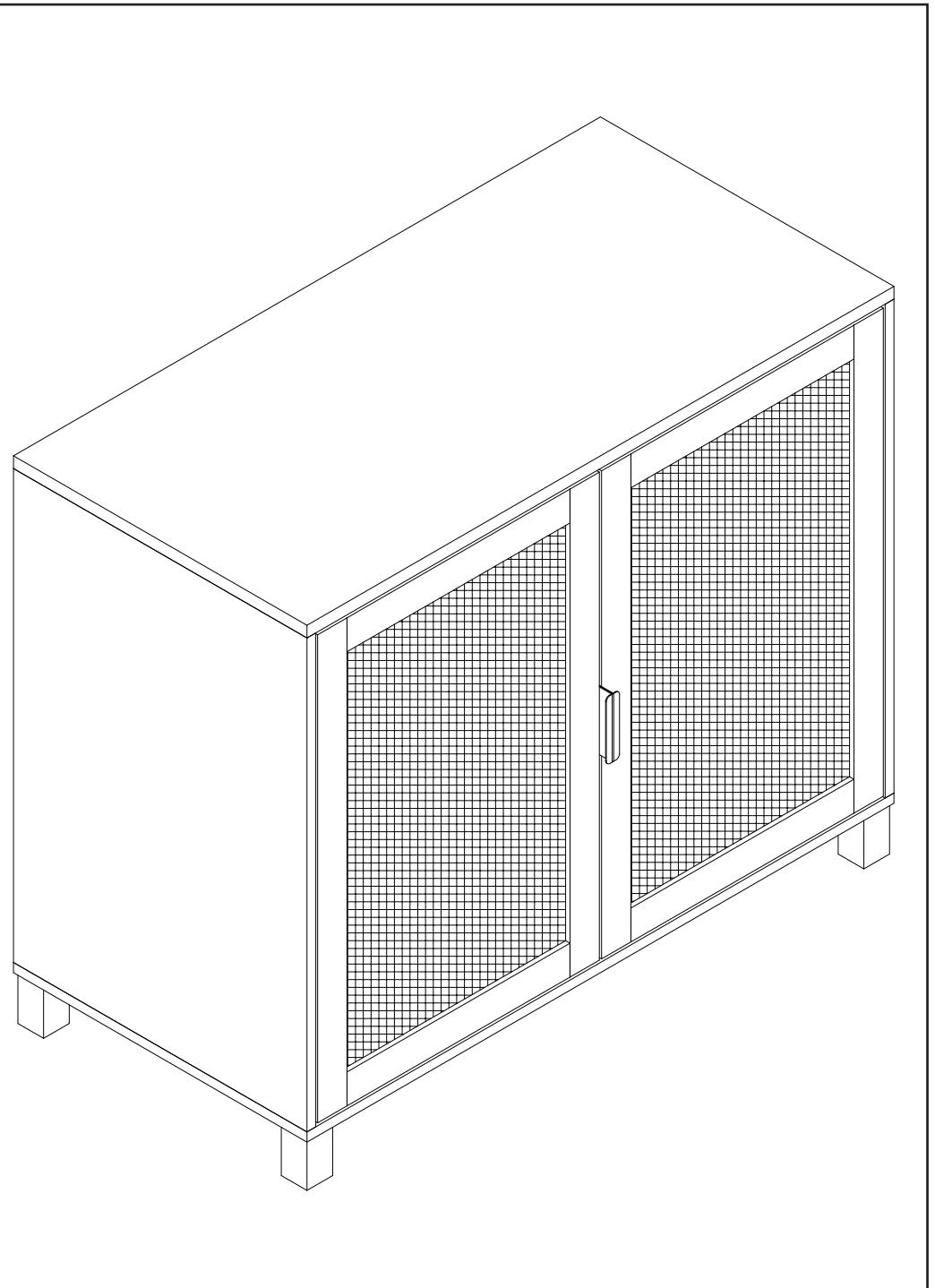
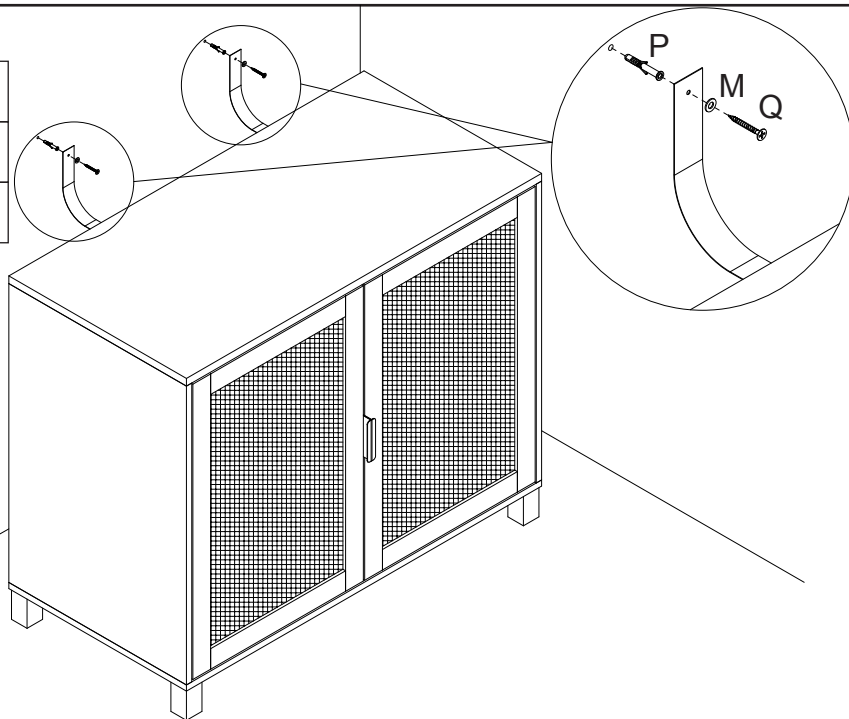

Conseils pour le réglage des charnières

Remarque : Lors du premier assemblage, il se peut que la porte gratte, se heurte ou soit mal alignée. Veuillez suivre les conseils ci-dessous :

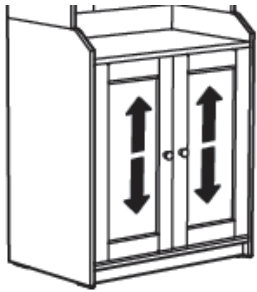

Ajustez la porte vers le haut et vers le bas

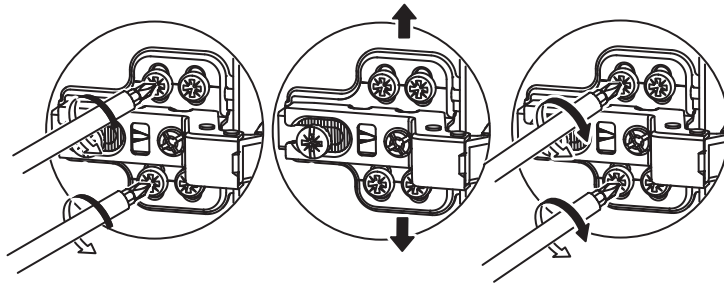

1. Desserrez légèrement les deux vis de fixation des deux charnières.
2. Fermez doucement la porte de l'armoire.
3. La porte étant toujours fermée, réglez la porte de l'armoire à la hauteur souhaitée.
4. Ouvrez à nouveau la porte de l'armoire, en veillant à ne pas la déboîter de sa position.
5. Resserrez les vis à la main.

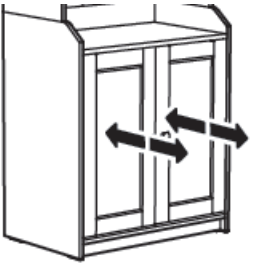

Déplacez la porte vers l'intérieur et vers l'extérieur

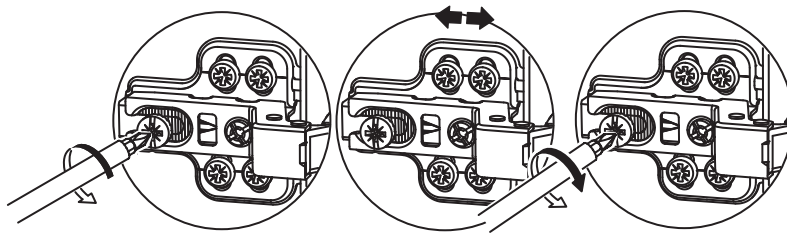

Si la porte ne rencontre pas le caisson en haut, réglez la charnière supérieure vers le caisson et/ou réglez la charnière inférieure en l'éloignant du caisson.
Si la porte a un jeu en bas, faites l'inverse.

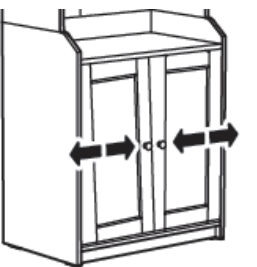

Déplacez la porte vers la droite ou vers la gauche

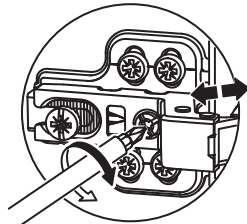

Vous pouvez régler une ou les deux charnières de chaque porte, en fonction de la correction nécessaire.

Si la porte semble pencher vers la droite, tournez la vis latérale de la charnière supérieure de manière à ce que la charnière se rapproche du côté du caisson, déplaçant ainsi le haut de la porte vers la gauche.

AVERTISSEMENT CONTRE LE BASCULEMENT DU MEUBLE :

- Il est fortement recommandé de fixer ce produit de manière permanente au mur.
- Veuillez demander l'avis d'un professionnel si vous avez un doute sur le dispositif de fixation à utiliser.
- Vérifiez régulièrement que les ancrages sont solidement maintenus.
- Utilisez des verrous de tiroir de sécurité pour empêcher les enfants de grimper.
- La stabilité des articles à queue peut être affectée par des tapis à poils épais ou des sols inégaux.
- Ne placez pas de téléviseurs non ancrés sur le meuble.

ATTENTION : Pour votre sécurité, lorsque vous fixez les ancrages, veuillez tenir compte des points suivants :

- Vérifiez les fils électriques ou la plomberie à l'intérieur du mur avant de percer des trous (en cas de doute, demandez l'avis d'un professionnel qualifié).



RISQUE DE BASCULEMENT

AVERTISSEMENT :
VEUILLEZ FIXER VOS MEUBLES
À L'AIDE DE LA FIXATION
MURALE FOURNIE.